

# Brookstone® Security WiFi Camera

USER MANUAL



FCC ID: 2AQ7B-IPC159



RoHS



#### FCC Statement:

1. This device complies with Part 15 of the FCC Rules. Operation is subject to the following two conditions: (1) this device may not cause harmful interference, and (2) this device must accept any interference received, including interference that may cause undesired operation.

Caution: The user is cautioned that changes or modifications not expressly approved by the party responsible for compliance could void the user's authority to operate the equipment.

Note: This equipment has been tested and found to comply with the limits for a Class B digital device, pursuant to part 15 of the FCC Rules. These limits are designed to provide reasonable protection against harmful interference in a residential installation. This equipment generates uses and can radiate radio frequency energy and, if not installed and used in accordance with the instructions, may cause harmful interference to radio communications. However, there is no guarantee that interference will not occur in a particular installation. If this equipment does cause harmful interference to radio or television reception, which can be determined by turning the equipment off and on, the user is encouraged to try to correct the interference by one or more of the following measures:

- Reorient or relocate the receiving antenna.
- Increase the separation between the equipment and receiver.
- Connect the equipment into an outlet on a circuit different from that to which the receiver is connected.
- Consult the dealer or an experienced radio/TV technician for help.

2. This equipment complies with FCC radiation exposure limits set forth for an uncontrolled environment. This equipment should be installed and operated with a minimum distance of 20cm between the radiator and any part of your body.

For more products please visit [www.brookstone.com](http://www.brookstone.com)

# WARRANTY INFORMATION

One Year Limited Warranty.

Customer Service: [help@smartpointco.com](mailto:help@smartpointco.com)

The BROOKSTONE trademark, names and logos are owned by BKST Brand Holdings LLC ©2022. All rights reserved

Manufactured, marketed and distributed by Smartpoint LLC, under license

Google, Android and Google Play are trademarks of Google LLC.

App Store® is a registered trademark of Apple, Inc

All trademarks and Registered trademarks are property of their respective owners  
Made in China

©Smartpoint LLC, 250 Liberty Street Metuchen NJ, Suite 1A

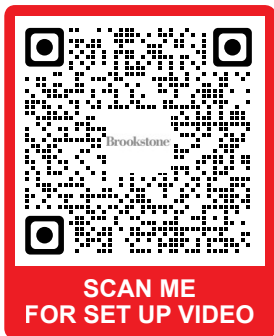

For more assistance on Troubleshooting,  
Connecting and Tips on Using your New Device,  
Scan QR code above or visit:

[www.smartpointco.com/faq-trouble-shooting](http://www.smartpointco.com/faq-trouble-shooting)

## SPECIFICATIONS

Model: BkWIFICAMWL2

Resolution: 1920x1080

Alarm: Motion detection

Viewing angle: 100° (Lens angle is adjustable)

Manually adjustable lens angle

Up: 25°

Down: 18°

Right: 20°

Left: 20°

Frame rate: Up to 15 fps

Sensor: 2.0 Megapixel

Audio: Microphone & Speaker built-in

Micro SD Card Storage: Up to 32GB

Compression: H.264

Power: AC 100V-240V

Operating Temperature: 50°F - 122°F(-10°C-50°C)

Indoor Use Only

Operating System:

Android™ 8.0 or higher, iOS 10.0 or higher

## FEATURES

- Wi-Fi remote controlled through App
- Adjustable Lens Angle
- Cordless, plugs directly into outlet
- Motion detection
- Sound detection
- Two way audio
- One-Touch Call Out button
- Live video
- Video recording
- Takes still photos
- Cloud storage or Micro SD Card storage

**Items included in package:**  
Camera, Reset Pin and User Manual.

# PRODUCT CONFIGURATION

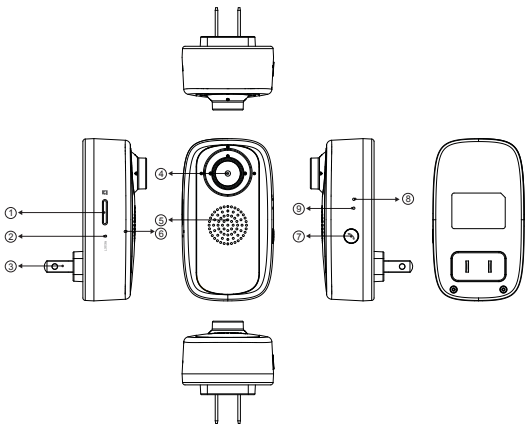

1. Micro SD Card Slot

2. Reset Hole

3. Power Plug

4. Camera Lens

5. Built-in Speaker

6. Built-in Microphone

7. One-Touch Call Out Button

8. Red LED

Working Indicator

9. Blue LED

Working Indicator

## DOWNLOAD APP

1. Android: download “Brookstone Smart” app on Google Play.
2. iPhone: download “Brookstone Smart” app from the App Store.



Brookstone Smart



# REGISTRATION AND LOGIN

1. Run the “Brookstone Smart” app from your smart phone.
2. Register and login.

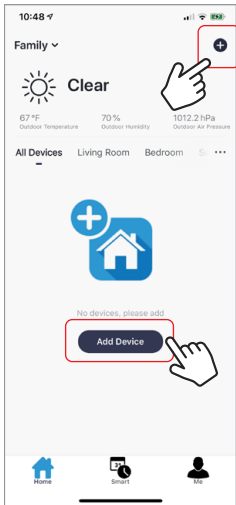
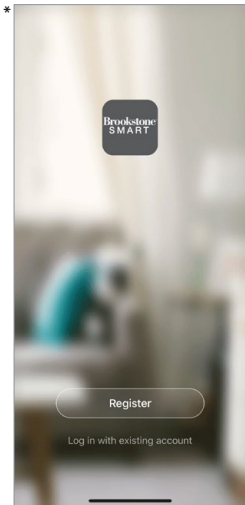

\*Screenshots may slightly differ from actual app.



# ADD DEVICE

1. Plug in Wi-Fi Camera into the wall and wait a few seconds. If the red light is not blinking, insert the provided pin gently into the reset hole for 3-5 seconds, then release. The light should then start blinking red fast. The camera is now ready to be set up.
2. Make sure phone is connected to your Wi-Fi network and that it is a 2.4GHz network.
3. Press the (+) symbol in the top right corner or “Add Device” in the middle of the screen and select the Smart Camera from the list of devices to add.



4. Press the “next step” button
5. Make sure phone is connected to the Wi-Fi network that the device will be connected to. Enter your password for the Wi-Fi network.
6. Follow the directions in the app and hold the QR code on the screen in front of the view of the camera.

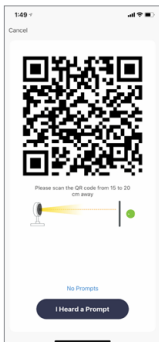
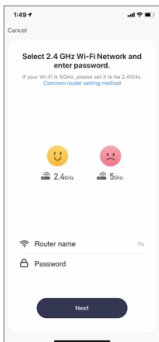
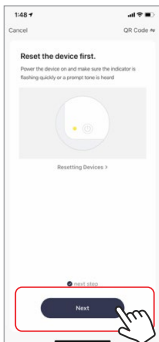

7. Connecting process will begin. Do not turn off Wi-Fi Camera or phone while connecting. Wait for connection process to complete.
8. Once device has been successfully added, name the device what you would like it to be called in the app. The Wi-Fi Camera is ready for use.

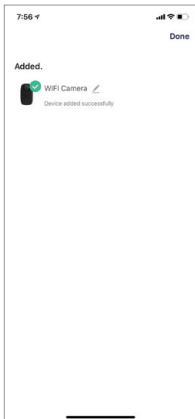
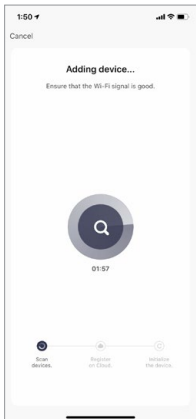

## ADJUSTABLE LENS ANGLE

The camera is equipped with a lens that can be manually adjusted to your desired direction.

Directions can be adjusted to the below angles.

Up: 25°

Down: 18°

Right: 20°

Left: 20°



## ONE-TOUCH CALL OUT BUTTON

When a person in front of the camera wishes to reach the app owner, they can press the call button to send out the request for two-way audio. When the app owner accepts the request, the camera will be activated. This feature can be used for in emergency situations.



# PUSH NOTIFICATIONS

1. You can turn on/off notifications for all devices connected to app by clicking on the “Me” button at the bottom right of the screen.
2. Then click on “Settings” button. From there you can turn on/off all notifications.
3. To view notifications in the app, click on “message center” on the “me” tab on the bottom.

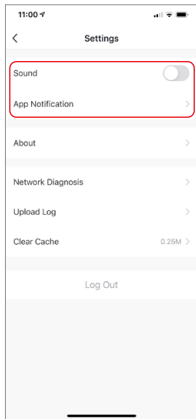
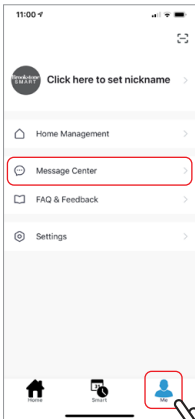

# REMOVE A DEVICE

1. From the home screen, click on the device you would like to remove.
2. Then click on the edit symbol on the top right of the screen.
3. From there you would then click the “Remove Device” button at the bottom of the screen.

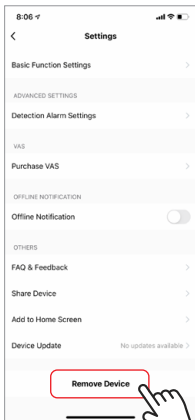
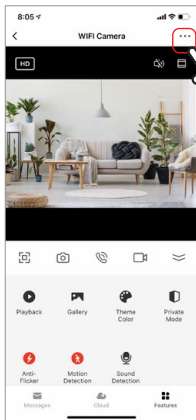

# APP FUNCTIONS

## Live Video

To view live video simply click on the device under “All devices” and select the camera you just added. Hit the full screen button in the top left corner to see your live footage at full screen on your phone.

To hide the control panel, you can press the top right button. To view the control panel again, press the same button again.

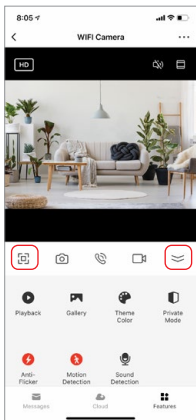
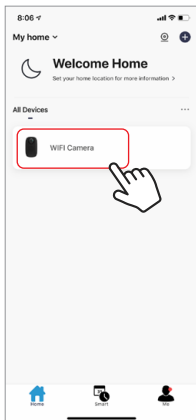



## Video Recording

To record video press the “camera” button at the top of the control panel. To end recording, press the “camera” button again. The video will be saved in the APP(iOS) or the photos and video section(Android). To view recordings, press “gallery” button.

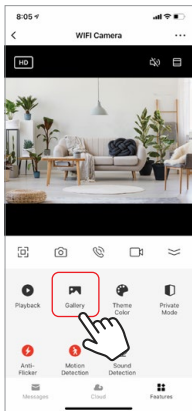
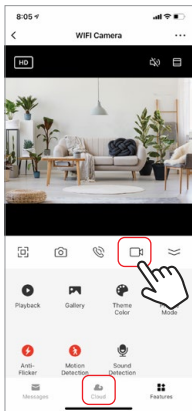

## Installing a Micro SD Card

To install a Micro SD Card, insert it into the slot on the side of the camera. (*Please see images below to make sure you have the correct type of memory card.*) Once you correctly insert it all the way it should click into place. To remove it, press down on it slightly and it will pop out. The camera can use any memory size of Micro SD Card up to 32 GB in size.

Once the Micro SD Card is installed you need to format it. To format the card, go to the settings of the camera by clicking on the icon at the top right corner of the camera screen, then click on "Storage Settings", then click on "Format".

*Images of what  
Micro SD Card Looks like.*

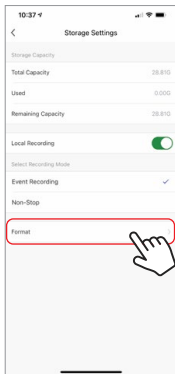

## Cloud Storage

If you don't have a Micro SD Card in the camera, Cloud Storage can be purchased by pressing the "Cloud" button on the bottom of the main screen. When a Cloud subscription is purchased all motion detection video is saved in the cloud and is kept safe and secure.

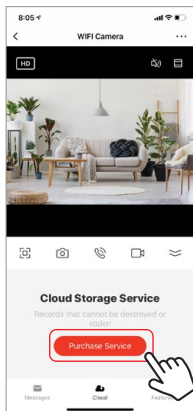
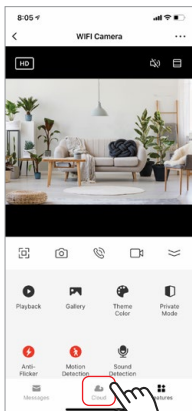

## Taking a Photo

To take a photo, press the “camera” button. The photo will be saved in the APP(iOS) or the photos and video section(Android). To view your photos, press the “gallery” button.

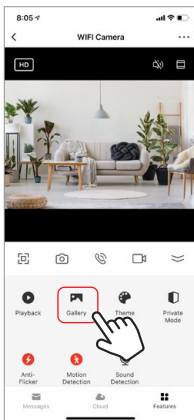
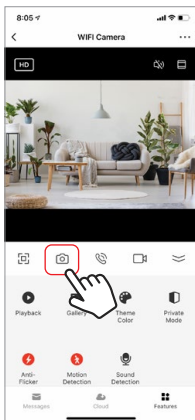

## Two Way Audio

To activate two way audio, press the “speak” button. When the button is orange, whatever you say into your phone will come out of the speaker on the camera. You can also hear at the same time any sounds from the live video on the camera.

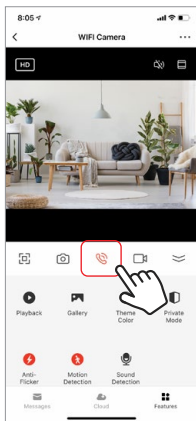
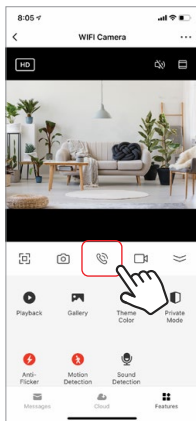

## Motion and Sound Detection

The camera uses infrared sensors when someone/something appears within its detection area. It also detects sound so you can hear if your dog is barking or if there is a break in while you are away. Push notifications will be sent to your phone once motion or sound is detected.

To access controls of the detection alarm settings, press the camera setting button at the top right. You can also get to this from pressing the “Motion Detection” or “Sound Detection” button on the main camera page. You can also set a time window of the day that the alarms will go off by pressing “Schedule” on this page.

To view videos recorded via motion detection press “Playback” on the main screen. You must have a Micro SD Card in the camera or have cloud storage enabled to view these saved videos.

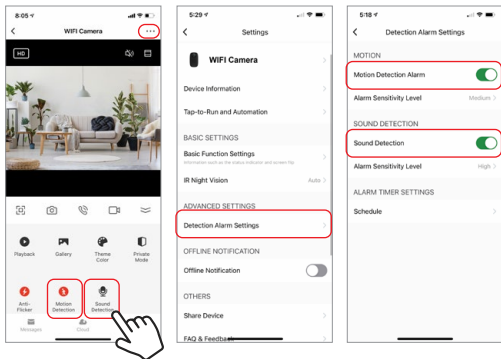

## Theme Color

The control panel can be set to “Light Mode” or “Dark Mode”. To change this, press “Theme Color” and a pop up menu will let you select light or dark mode.

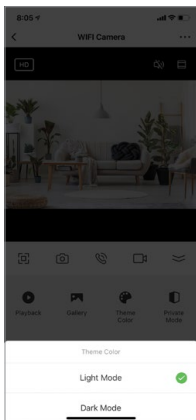
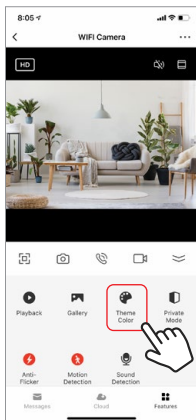

## Private Mode

The camera has a private mode. When the private mode is turned on the camera goes to sleep. You can turn this mode on from the main screen by pressing “Private Mode”

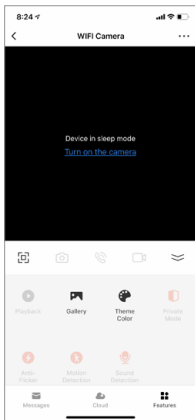
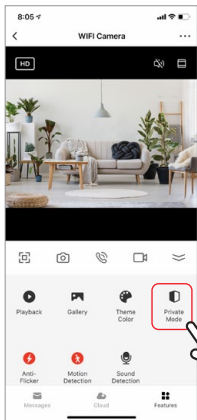



## Anti-Flicker

The camera has an “Anti-Flicker” setting if you notice flickering in your footage. Select it from the main screen and choose which frequency works best.

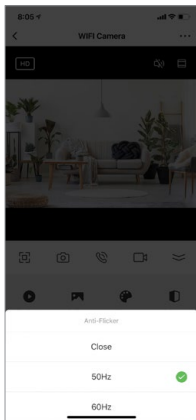
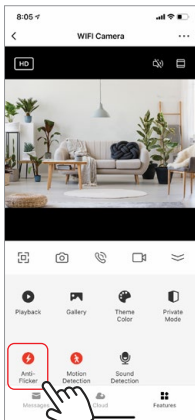

## Hub controls (sound, video quality, zoom in/out)

You can control features from the live video feed. There is a volume button that is used to mute and unmute the live feed. There is also a button for the video quality and it can be used to switch between standard and high definition resolution. In the top right there is also a button that can be used for zooming in or out on the footage.

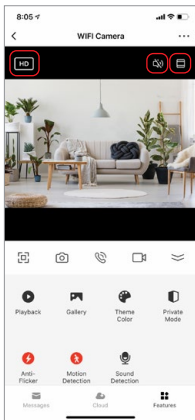

## Sharing the Device

To share access to your camera with someone else's Brookstone Smart account, press the camera settings button at the top right of the main camera screen. Then hit "Share Device". On the next page press "Add Sharing" at the bottom. After that, enter the email on the person's Brookstone Smart account that you would like to share the camera with. They will get a notification to accept and after that the other person will have access to view your camera through the Brookstone Smart app on their phone.

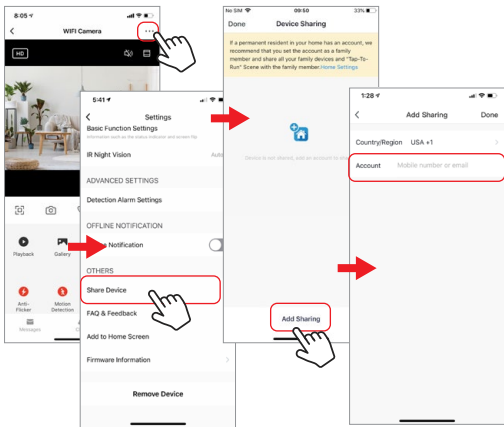

# CONNECTING TO A NEW NETWORK

## **How to change the WiFi Network of the camera**

If you need to change the WiFi network that your device is connected to, delete the device from the Brookstone Smart App. Then start the set up process again as if you were adding a new device when you are connected to the new WiFi Network that you want to the connect your existing device to. Your device will now remember the new WiFi Network.

Once a WiFi Network has been successfully connected to your device, it will remember it even if you unplug it. So if you want to move it to a different part of your home, unplug it after you have set it up and then plug it in some where else in your home and it will automatically connect the WiFi.