

**SMARTPOINT**

# SmartSolar Pathway Lights

USER MANUAL



FCC ID: 2ANDL-BT3L



RoHS



#### FCC Statement:

1. This device complies with Part 15 of the FCC Rules. Operation is subject to the following two conditions: (1) this device may not cause harmful interference, and (2) this device must accept any interference received, including interference that may cause undesired operation.

Caution: The user is cautioned that changes or modifications not expressly approved by the party responsible for compliance could void the user's authority to operate the equipment.

Note: This equipment has been tested and found to comply with the limits for a Class B digital device, pursuant to part 15 of the FCC Rules. These limits are designed to provide reasonable protection against harmful interference in a residential installation. This equipment generates uses and can radiate radio frequency energy and, if not installed and used in accordance with the instructions, may cause harmful interference to radio communications. However, there is no guarantee that interference will not occur in a particular installation. If this equipment does cause harmful interference to radio or television reception, which can be determined by turning the equipment off and on, the user is encouraged to try to correct the interference by one or more of the following measures:

- Reorient or relocate the receiving antenna.
- Increase the separation between the equipment and receiver.
- Connect the equipment into an outlet on a circuit different from that to which the receiver is connected.
- Consult the dealer or an experienced radio/TV technician for help.

2. This equipment complies with FCC radiation exposure limits set forth for an uncontrolled environment. This equipment should be installed and operated with a minimum distance of 20cm between the radiator and any part of your body.

For more products please visit [www.smartpointco.com](http://www.smartpointco.com)

## SPECIFICATIONS

Model: SPSSPATHLTS-2PK

Lamp Source: 1 warm white LED 2700K,  
1 cool white LED 7000K, 1 color changing LED

Battery Capacity: 600mAh(Li-) rechargeable

Lumens: 15 at normal white

Lamp Color: RGBW

Battery Voltage: 3.7V

Protocol: Bluetooth Mesh

Solar Panel: 0.4W/5V poly crystalline solar panel

Control Distance: 60-85 feet(with no obstacles in way)

IP Rating: IP44

Operating Temperature: -4°F ~ 122°F

## WARRANTY INFORMATION

One Year Limited Warranty.

Customer Service: 732-994-2301; email: [help@smartpointco.com](mailto:help@smartpointco.com)

Manufactured, marketed and distributed by Smartpoint LLC, under license.

Google and Google Play are trademarks of Google LLC.

App Store® is a registered trademark of Apple, Inc.

All trademarks and registered trademarks are property of their respective owners.

Made in China

©Smartpoint LLC,  
250 Liberty Street, Suite 1A  
Metuchen, NJ 08840

## FEATURES

- Bluetooth remote controlled
- Changes to any color or white
- Dimmable
- Syncs with music
- Light Sensor - automatically turns on when dark and turns off when light
- Rechargeable battery that recharges from the solar panel
- Weatherproof

# PRODUCT CONFIGURATION

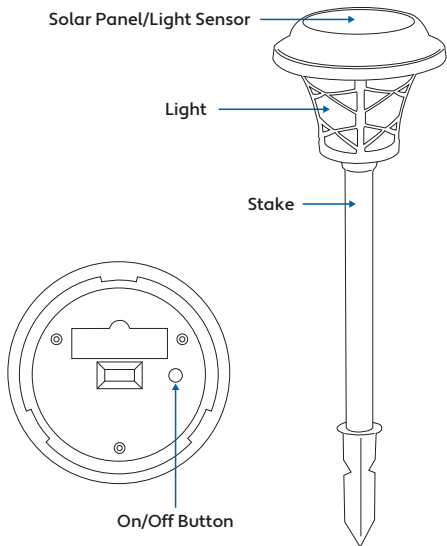

## DOWNLOAD APP

1. Android™: download “Smartpoint Home” app on Google Play.
2. iPhone: download “Smartpoint Home” app from the App Store.



Smartpoint Home



Available on the  
App Store



GET IT ON  
Google Play

## REGISTRATION AND LOGIN

1. Run the “Smartpoint Home” app from your smart phone.
2. Sign up and login.

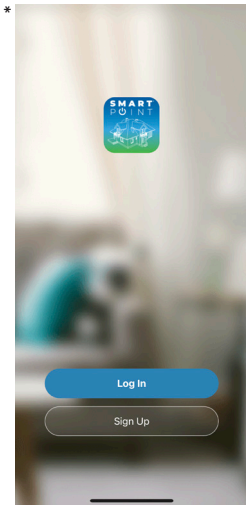

\*Screenshots may slightly differ from actual app.

## ADD DEVICE

1. Make sure Bluetooth is turned on in your phone's settings.
2. Unscrew the top of the light. Remove the pull-tab, find the power button and turn the light on and off 5-6 times and then leave it on. *(If light does not turn on it may need to be charged. Place in sunlight to charge. Light takes about 6-8 hours of sunlight to fully charge)*
3. Then on the home screen of the app, press the (+) in the top right corner or "Add Device" in the middle.
4. Once you are on the page with all the devices to add, wait a few seconds and a window to add the device will pop up.. When device window pops up with the light to add, press "Go to add"

### **NOTE**

***(During set up process, cover the light sensor or turn light upside down so light thinks it is dark)***



5. On the next screen press the (+) symbol to begin adding the Solar Light.
6. Connecting process will begin. Do not turn off Solar Light while connecting. Wait for connection process to complete. *(It may help to be about 4-6 feet away from light when connecting.)*

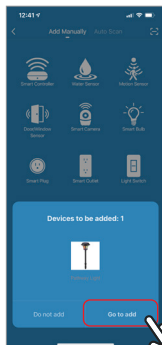
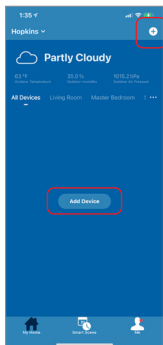

- Once device has been successfully added you can begin using it.

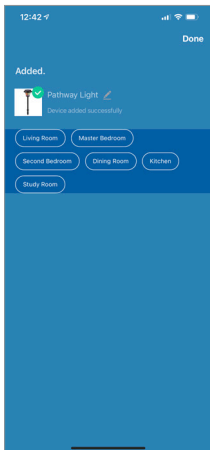
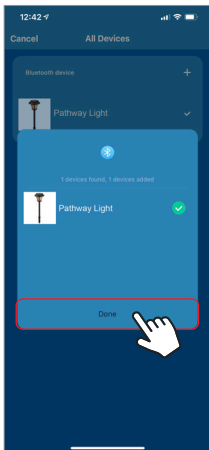

## CONTROLLING THE DEVICE

To access the settings of the Smart Solar Light, press the settings icon in the top right corner.

You can turn on an energy saving feature that will make the light a little dimmer to conserve power at all times. That is located under the settings icon.

The battery percentage of the light is also listed on the color and white control panels of the light controls. It is shown near the top and also shows a power gauge. When the gauge is full, the battery is full and when the battery gets low it starts to empty.

**NOTE**  
*(Light controls can only be accessed when light is in the dark or if solar panel is covered.)*

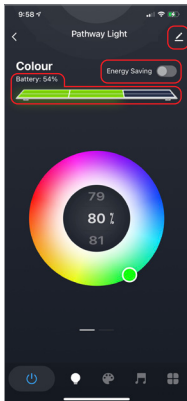

## COLOR AND WHITE MODES

There are four modes for the Solar Light.

**Color, White, Scene and Music modes.**

**Color mode** lets you change the color and brightness of the light. Swipe up or down to change brightness percentage.

**White Mode** makes the light white. Swipe up or down to change brightness percentage.

*(To select color modes you can select the Light Bulb icon at the bottom. You can switch between color and white modes by swiping left or right on the dashes below the color picker)*

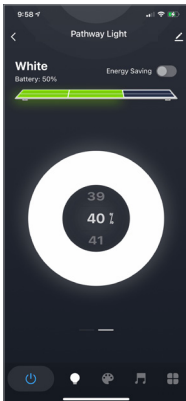
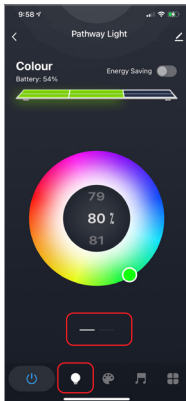

## SCENE AND MUSIC MODES

**Scene mode** has preprogrammed color settings to pick from. You can also create a custom scene.

**Music mode** changes light to the rhythm of music the phone speaker hears.

*(To select these modes you can select the Paint and Music icons at the bottom.)*

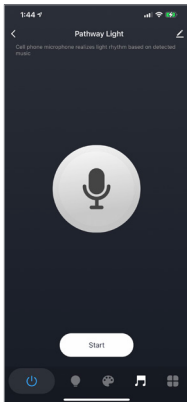
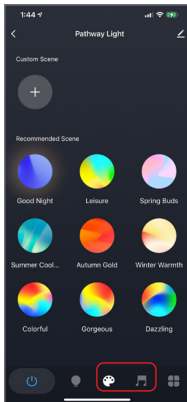

# GROUPING MULTIPLE LIGHTS TOGETHER

If you have multiple solar lights you can group them into one group so you can control all of the settings of all the lights at the same time.

To group multiple lights together be sure to add all of the lights to your Smartpoint Home App. Then select one of the lights and press the settings button in the top right hand corner. Then press "Create Group". After that, select the lights you want to add to the group and press "Save". Next, name the group and then press save. The group will now show up on the home screen of your app. When you click on the group, whatever settings you save in the group applies to all of the lights in the group.

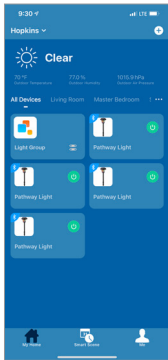
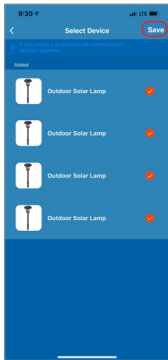
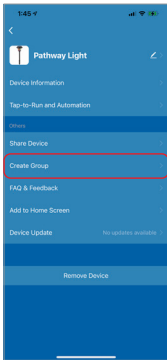

# PUSH NOTIFICATIONS

1. You can turn on/off notifications for all devices connected to app by clicking on the “Me” button at the bottom right of the screen.
2. Then click on “Settings” button. From there you can turn access notification settings.

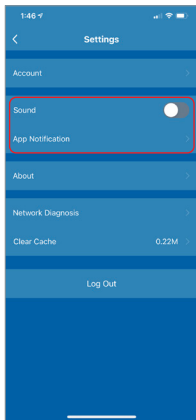
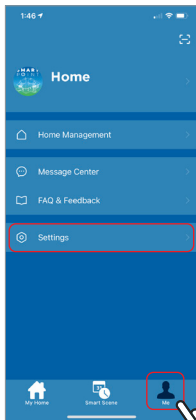

# REMOVE THE DEVICE

1. From the home screen, click on the Solar Light you would like to remove.
2. Then click on the edit symbol on the top right of the screen.
3. From there you would then click the “Remove Device” button at the bottom of the screen.

